



35 Series Installation

Auto racing remains a very dangerous sport regardless of any protective devices you may use. Please read the instructions very carefully and if you have any questions, please contact Kirkey Racing Fabrication Inc. 1-800-363-4885.

FAILURE TO COMPLY WITH THESE INSTRUCTIONS MAY CAUSE SERIOUS INJURY OR DEATH

These components (when installed correctly) are designed to reduce injury-producing movement of the upper body and head during a racing impact, but no device or component can prevent all injuries that may occur in auto racing.

Please read instructions before you start assembling seat.

Setting the shoulder restraint height:

You have the choice of various positions that you can set the height of the shoulder restraints, (see photo 1). Ideally you want the shoulder restraint positioned level with the driver's shoulders, (see photo #2). With the restraint at the proper height fasten the back of the seat to the bottom using the pre-punched holes, (see photo #2) and six of the 3/16" x 1/2" bolts provided. **The back section goes on the outside of the bottom section.** Use a tapered punch to align holes if necessary. To make alignment easier do not tighten bolts until they are all in place.

Setting the head restraint height:

You have the choice various head positions that you can set the height of the head restraint, (see photo #3). You can also adjust the pitch using the oblong holes. You want the head restraints positioned level with the driver's cheek bone. Have the driver look to the left and to the right to ensure that their peripheral vision is not obstructed. If peripheral vision is obstructed adjust accordingly. With the restraint at the proper height fasten the head restraint to the shoulder restraint using the pre-punched holes and four of the 1/4" x 3/4" bolts provided. **Two bolts per side must be used when setting vertical position. Use Loctite on bolts, and check for tightness regularly.** To make alignment easier do not tighten bolts until they are all in place.

<u>Hardware list:</u>	6- 3/16" x 1/2" bolts
	6- 3/16" lock nuts
	4- 1/4" x 3/4" bolts

Foam insert kit:

Included with the 35 series is a four-piece foam insert kit (see photo #4). These inserts can be used if the driver is between seat sizes and is loose in the seat. You can use all four inserts to add 1", or use them on one side only to add 1/2". Simply remove as the driver grows to extend the life of the seat. The shoulder restraint cover also has a removable foam insert.

Photo # 1

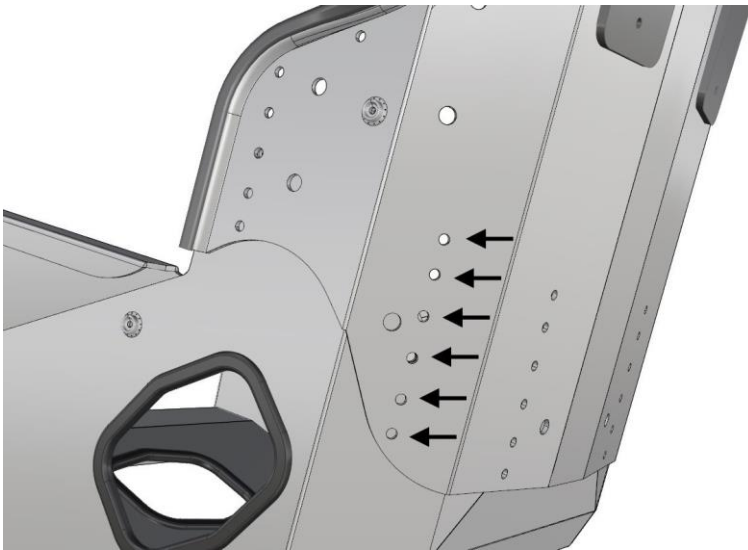

Photo # 2

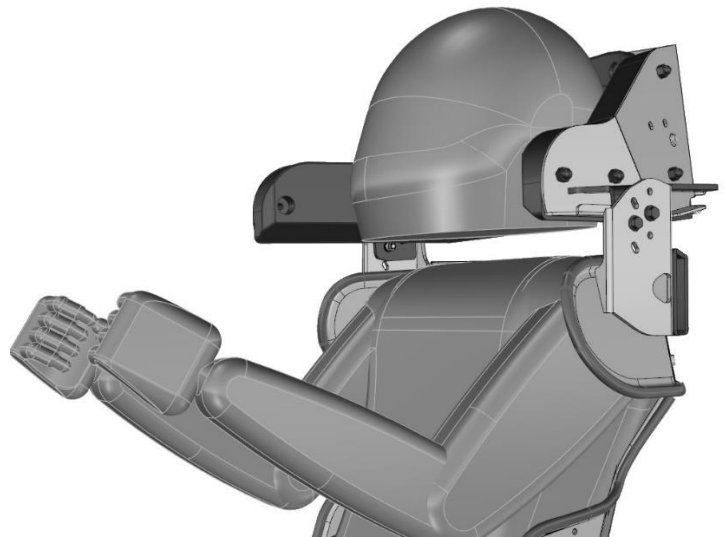

Photo # 3

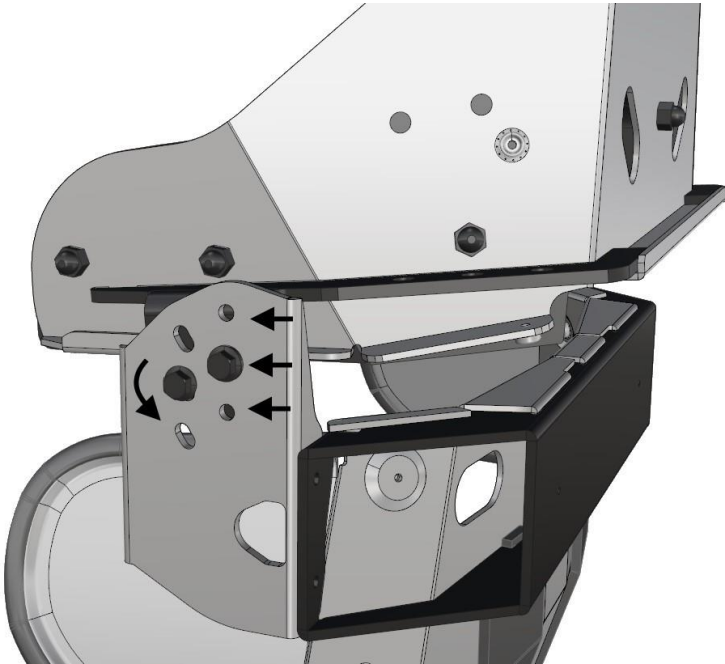
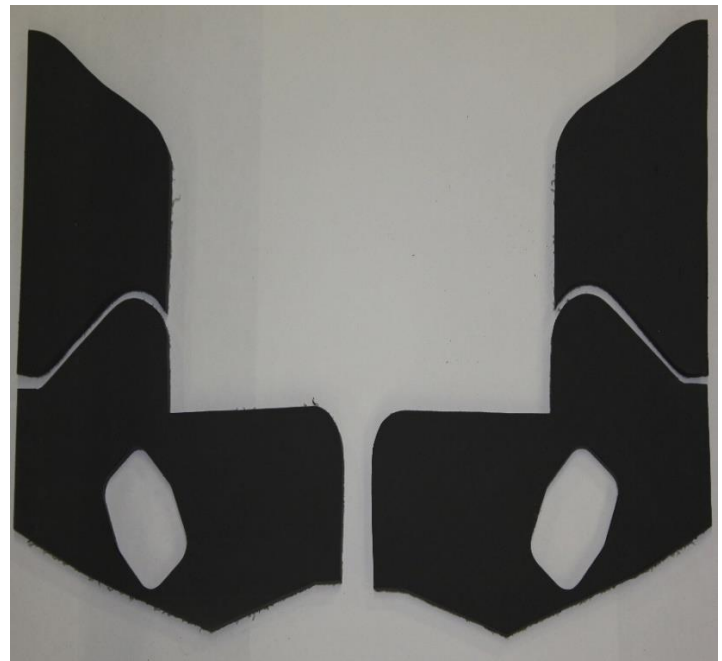

Photo # 4



MOUNTING INSTRUCTIONS

For the bottom of the seat, we recommend using four bolts (min. 5/16"/8mm) directly through the bottom of the seat to the frame or roll cage (spread the bolts out as far as possible to distribute the load).

For the back we recommend at least three bolts, (min. 5/16"/8mm) in shoulder box structure. We also make a bracket, Pt.# 99218 for this as well. **NEVER** mount to sheet metal. **If you are not qualified to perform such fabrication have the installation done by an expert familiar with the requirements of such installation.**

We DO NOT recommend the use of stock sliders and adjusters.

Be sure to check with your sanctioning body and/or track for their rules and regulations on seat mounting.