

80/81/83 Series Installation



Auto racing remains a very dangerous sport regardless of any protective devices you may use. Please read the instructions very carefully and if you have any questions, please contact Kirkey Racing Fabrication Inc. 1-800-363-4885.

FAILURE TO COMPLY WITH THESE INSTRUCTIONS MAY CAUSE SERIOUS INJURY OR DEATH

These components (when installed correctly) are designed to reduce injury-producing movement of the upper body and head during a racing impact, but no device or component can prevent all injuries that may occur in auto racing.

Please read instructions before you start assembling seat.

Setting the shoulder restraint height:

You have the choice of five positions that you can set the height of the shoulder restraint. Ideally you want the shoulder restraint positioned level with the driver's shoulders, (see photo #1). With the restraint at the proper height fasten the back of the seat to the bottom using the pre-punched holes, (see photo #3) and eight of the 3/16" x 1/2" bolts provided. To make alignment easier do not tighten bolts until they are all in place.

Setting the head restraint height:

You have the choice of two positions that you can set the height of the head restraint. You want the head restraints positioned level with the driver's cheek bone, (see photo #2). Have the driver look to the left and to the right to ensure that their peripheral vision is not obstructed. If peripheral vision is obstructed adjust accordingly. With the restraint at the proper height fasten the head restraint to the shoulder restraint using the pre-punched holes and four of the 5/16" x 3/4" bolts provided. To make alignment easier do not tighten bolts until they are all in place.

Attaching the rib braces:

The rib braces are cable tied to the bottom of the seat. Attach the rib braces to the seat using the remaining 3/16" x 1/2" bolt kit supplied, (see photo #3).

Hardware list:

16- 3/16" x 1/2" bolts

16- 3/16" lock nuts

4- 5/16" x 3/4" bolts

4- 5/16 flange nuts

4- 5/16" washers

MOUNTING INSTRUCTIONS

For the bottom of the seat there are two ways that you can mount this seat. You can use four bolts (min. 5/16"/8mm) directly through the bottom of the seat to the frame or roll cage (spread the bolts out as far as possible to distribute the load). Or you can use side mounts, Pt.# 99214, (see photo #4).

For the back we recommend at least three bolts, (min. 5/16"/8mm) in shoulder box structure. We also make a bracket, Pt.# 99210 for this as well (see photo #5). NEVER mount to sheet metal. **If you are not qualified to perform such fabrication have the installation done by an expert familiar with the requirements of such installation.**

We DO NOT recommend the use of stock sliders and adjusters.

Be sure to check with your sanctioning body and/or track for their rules and regulations on seat mounting.

Photo #1

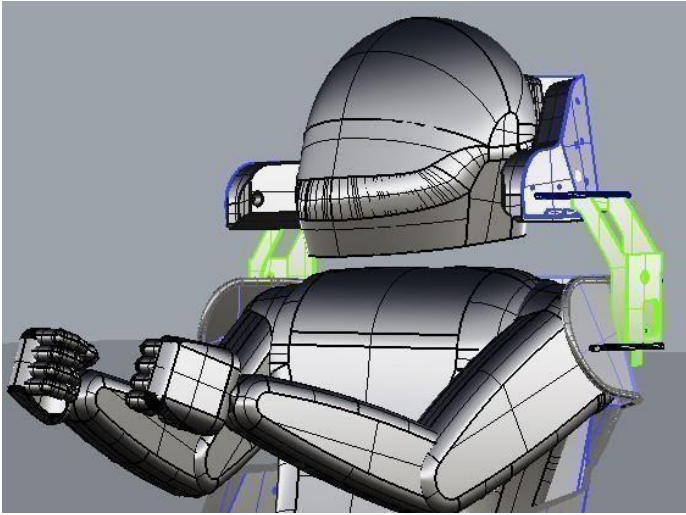

Photo #2

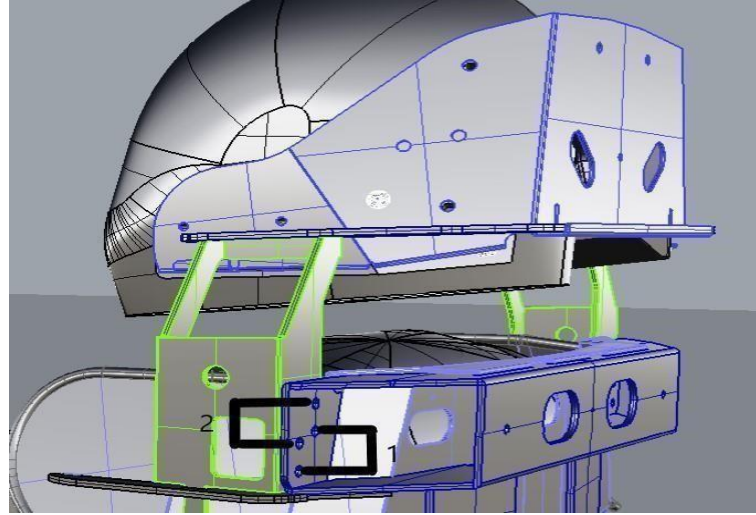

Photo #3

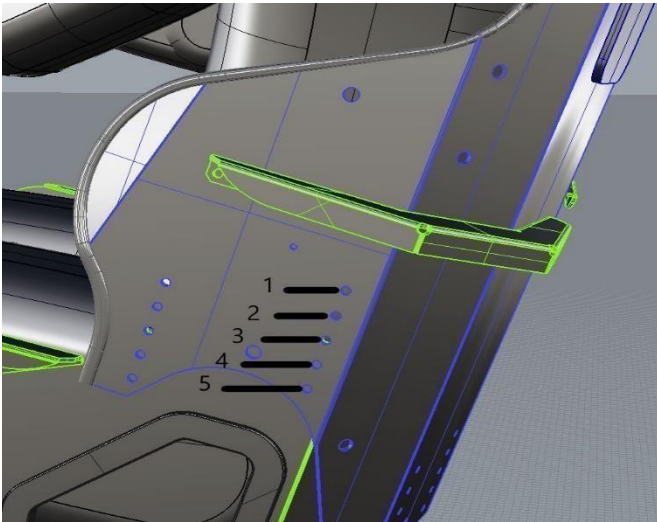

Photo #4 # 99214 Floor Mount Brackets

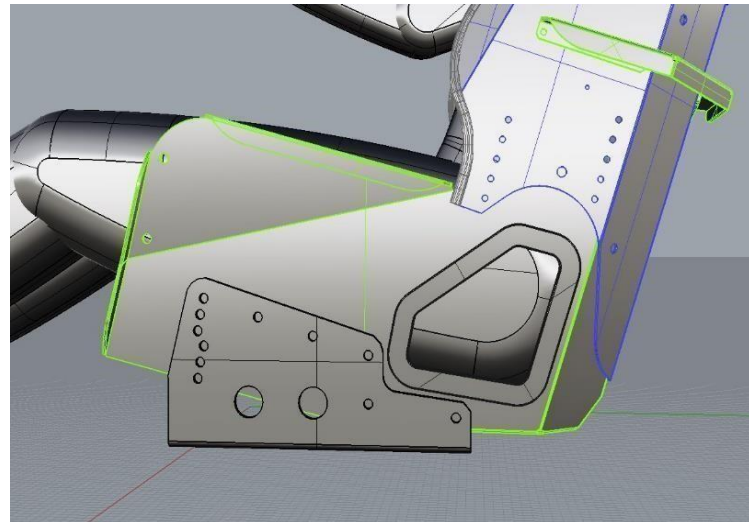
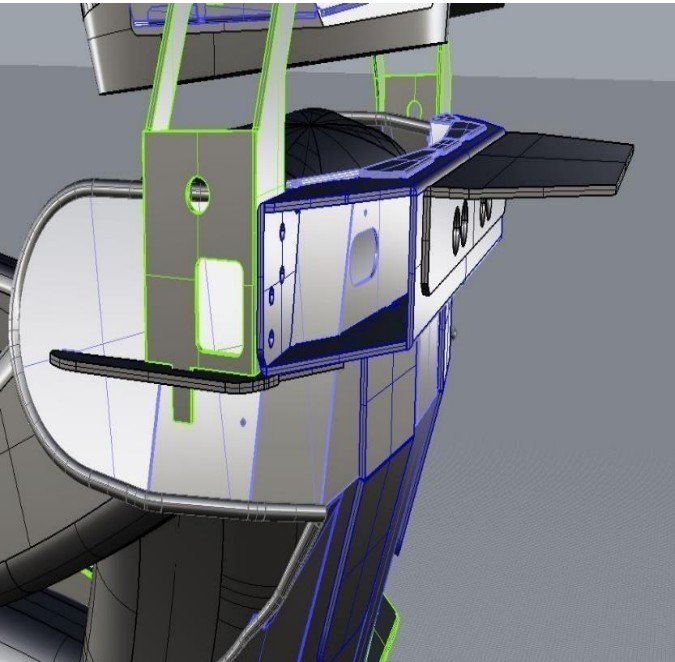

Photo #5 #99212 Rear Seat Mount



OPTIONAL ACCESSORIES

DESCRIPTION

PART #

99212-	REAR SEAT MOUNT BRACKET
99214-	FLOOR SEAT MOUNT BRACKETS
80RH1XP-	RIGHT SIDE PAD W/ EXTRA 1" FOAM
02100-	RIGHT SIDE LEG RESTRAINT
02111-	BLACK CLOTH COVER FOR 02100
02200-	LEFT SIDE LEG RESTRAINT
02211-	BLACK CLOTH COVER FOR 02200